

ATLAS MANIPULATOR 7F

ENVIRONMENTLY FRIENDLY
NO HYDRAULIC SLIP-RING
CAN BE OPERATED AS A RATE MANIPULATOR



Description

The Atlas series of manipulators is suited to work with the highest performing vehicles under the most demanding conditions.

The Atlas manipulator is known as a strong and reliable manipulator which is a perfect alternative where you need strength, perfection, range, and not at least a low operation cost.

It is possible to setup the manipulator with several types of grippers. (7.8-in Four Finger / 11.2-in Four Finger / 6-in Parallel & 3 Finger Imenco Jaw)

Typical Operations

- ▣ ROV
- ▣ Subsea Wire handling
- ▣ Rough operations

Features

- ▣ Tough and Durable
- ▣ Environmentally friendly
- ▣ Compact Design
- ▣ Service & User Friendly
- ▣ Low operating cost
- ▣ Left-Hand & Right-Hand configurable options

SPECIFICATIONS

Atlas Manipulator 7F

Arm Specification

Type	Atlas Manipulator 7F
Part number	ARM-ATLAS
Materials	Anodized Aluminum, Titanium, Stainless Steel
Fluid	Mineral / Glycol, or Synthetic
Weight	In Air: 73Kg / In Water: 50Kg
Standard Dept	6,500 msw
Reach	1.675 m
Lift at Full Extension	250 Kg
Maximum Lift, Nominal	500 Kg
Standard Gripper Opening	198 mm
Grip Force, Nominal	205 Nm
Wrist Rotate, Continuous	6-35 rpm

Actuator Function

Azimuth	Linear, 120°
Shoulder Pitch	Linear, 135°
Elbow Pitch	Linear, 135°
Wrist Pitch	Linear, 120°
Wrist Yaw	Linear, 120°
Wrist Rotate	Gerotor, 360°
Gripper, Standard	Linear, 198 mm

Hydraulic Specifications

Max Pressure	207 Bar / 3000 PSI
Available Flow	5.7 - 19 lpm
Max. Fluid Temperature	54°C
Fuid Cleanliness	ISO 4406 14/11

Hydraulic Connections

Line 1-15	15x JIC 04 Male
-----------	-----------------

Gripper Options

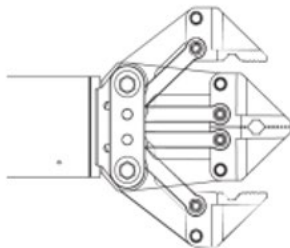

6-in Parallel

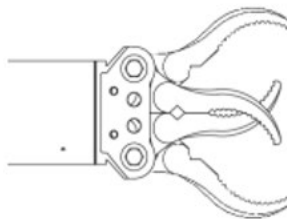

7.8-in Four Finger Intermeshing

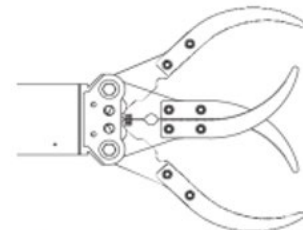

11.2-in Four Finger Intermeshing



IMENCO 3-Finger Jaw

SPECIFICATIONS

Atlas Manipulator 7F

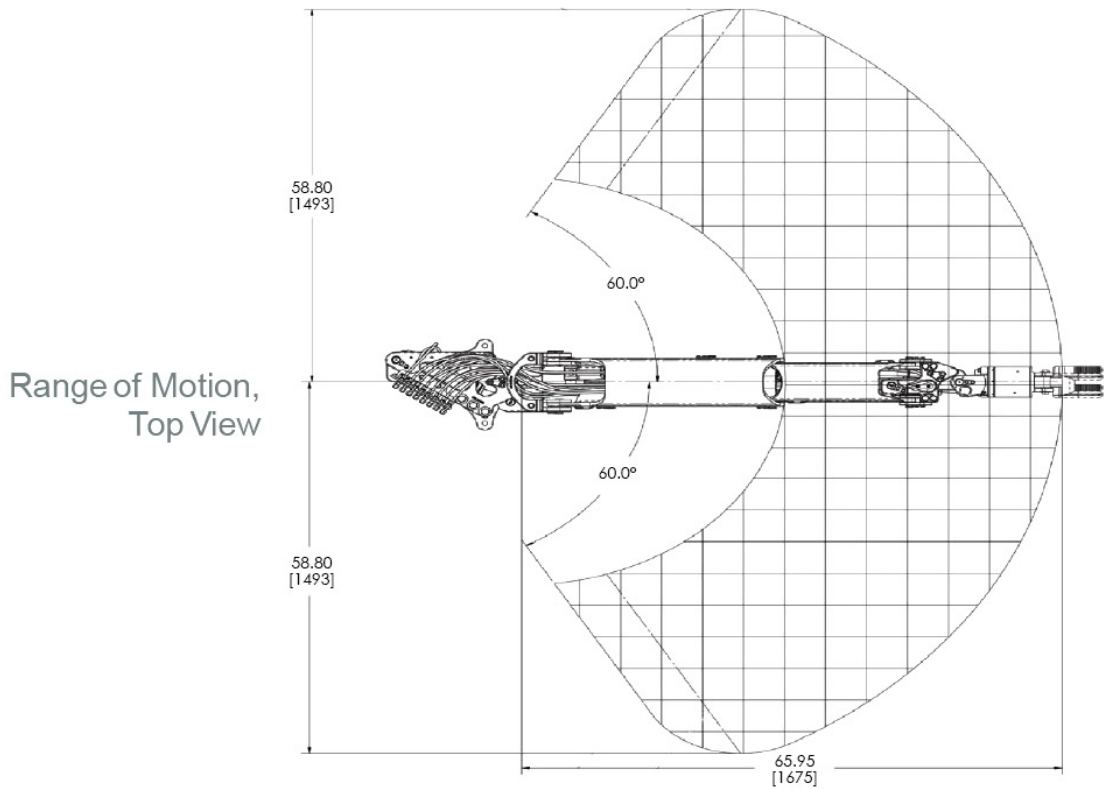
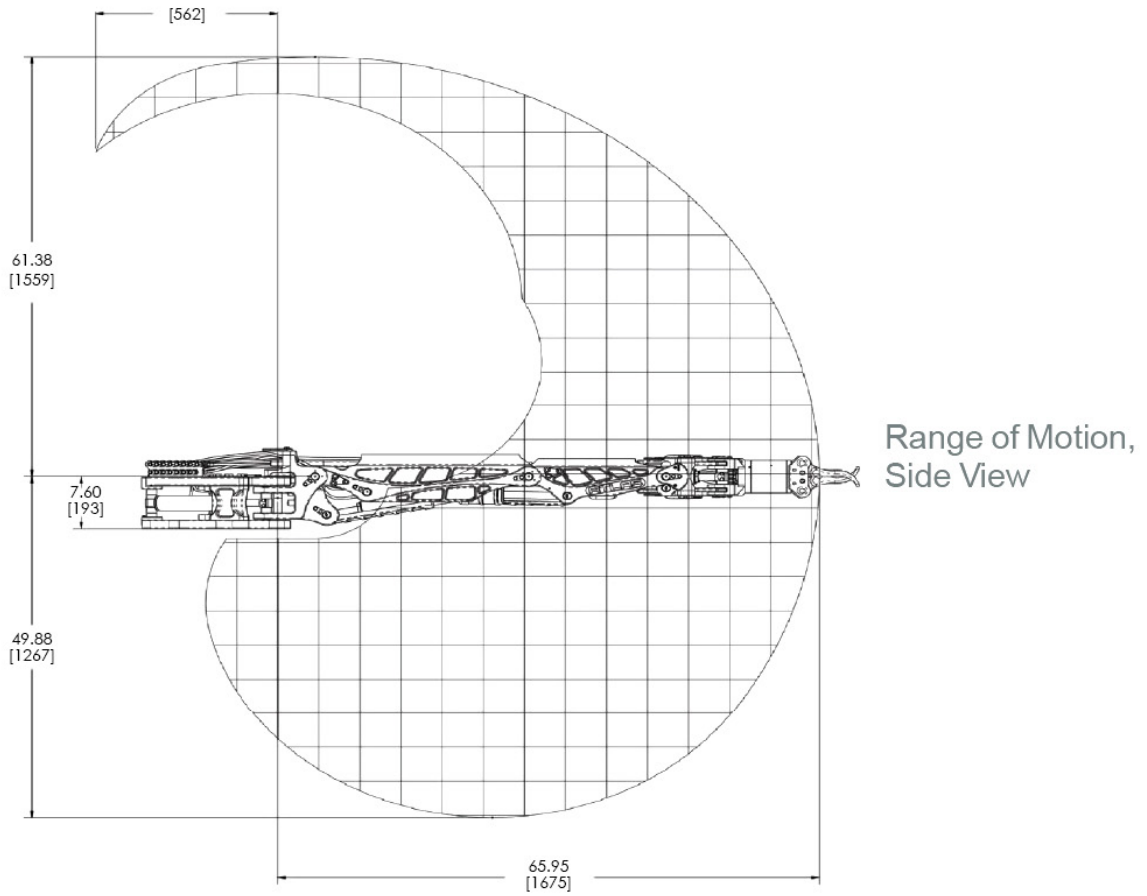

TechnipFMC.com
© Copyright TechnipFMC 2021. v 1.0. All rights reserved.

Schilling Robotics ATLAS 7P and 7R Manipulators | 3

SPECIFICATIONS

Atlas Manipulator 7F

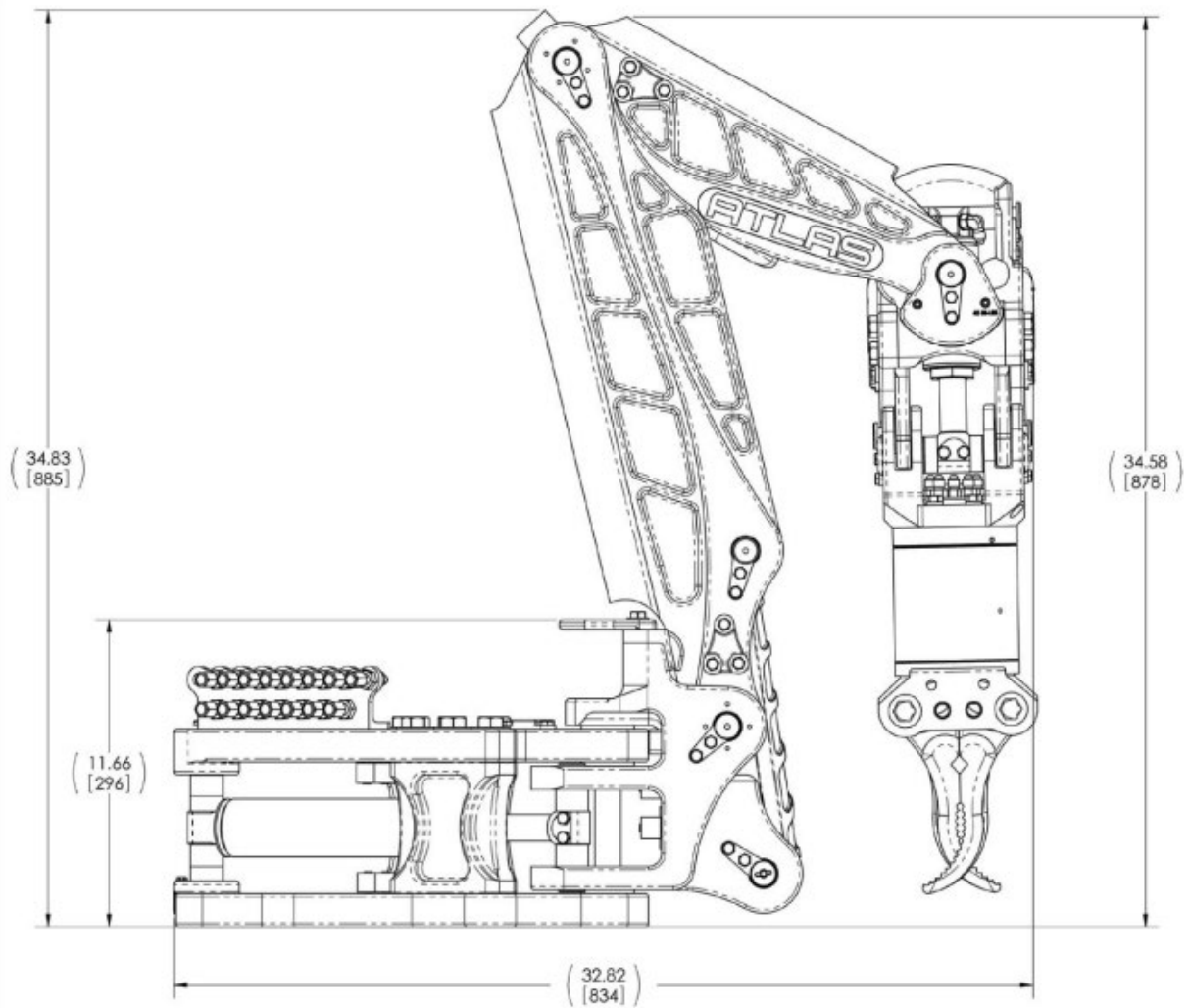

Dimensions with Arm Stowed