

5T SUBSEA WINCH

50 KN/5T
SUBSEA WINCH
ROV OPERATED

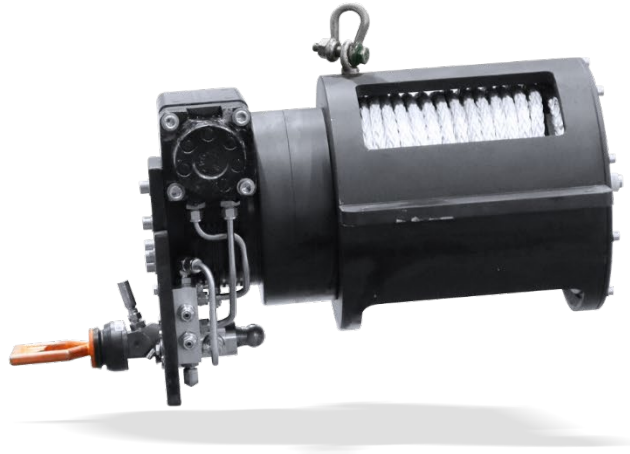

Description

The 5-ton subsea winch is compact and lightweight. It features a well-designed mounting solution that ensures easy and reliable installation. The winch is operated by an ROV using a hot stab.

It comes equipped with 25 meters of 14 mm TIMM Acera rope. Other rope types are available upon request. For operations where the winch is intended to be used as a standalone unit, we can provide support with a frame and counterweight.

Typical Operations

- Pulling Operations

Features

- Pulling Force 5T
- Counter-balance valve for break function
- Depth rated to 2000 MSW
- Ø35 2-port Hot Stab Integration
- Mounting flanges

■ The specification details are illustrative for marketing purpose only. Actual equipment may be different as a result of product improvement or other reasons. Specific interface and performance information should be reconfirmed at time of order placement. Envirent AS, Robotvegen 16, 4340 Bryne, +47 477 77 500, sales@envirent.no

SPECIFICATIONS

5T SUBSEA WINCH

General Technical Specifications

Type	5T Subsea Winch
Part Number	LIFT-WIN-5
Dimensions L x W x H	610 mm x 405 mm x 490 mm
Weight in air / submerged	122 kg / 81,5 kg
Depth Rating	2000 MSW

Hydraulic Specifications

Max. Input Pressure	140 Bar
Max. Supply Flow	15 L/min
Pull Force @ 140 Bar	5 Ton

Hydraulic Interface

Connection Reeling in	Ø35 DP Hot Stab
Connection Reeling out	Ø35 DP Hot Stab
Gear Oil Filling Point	¼» Swagelock

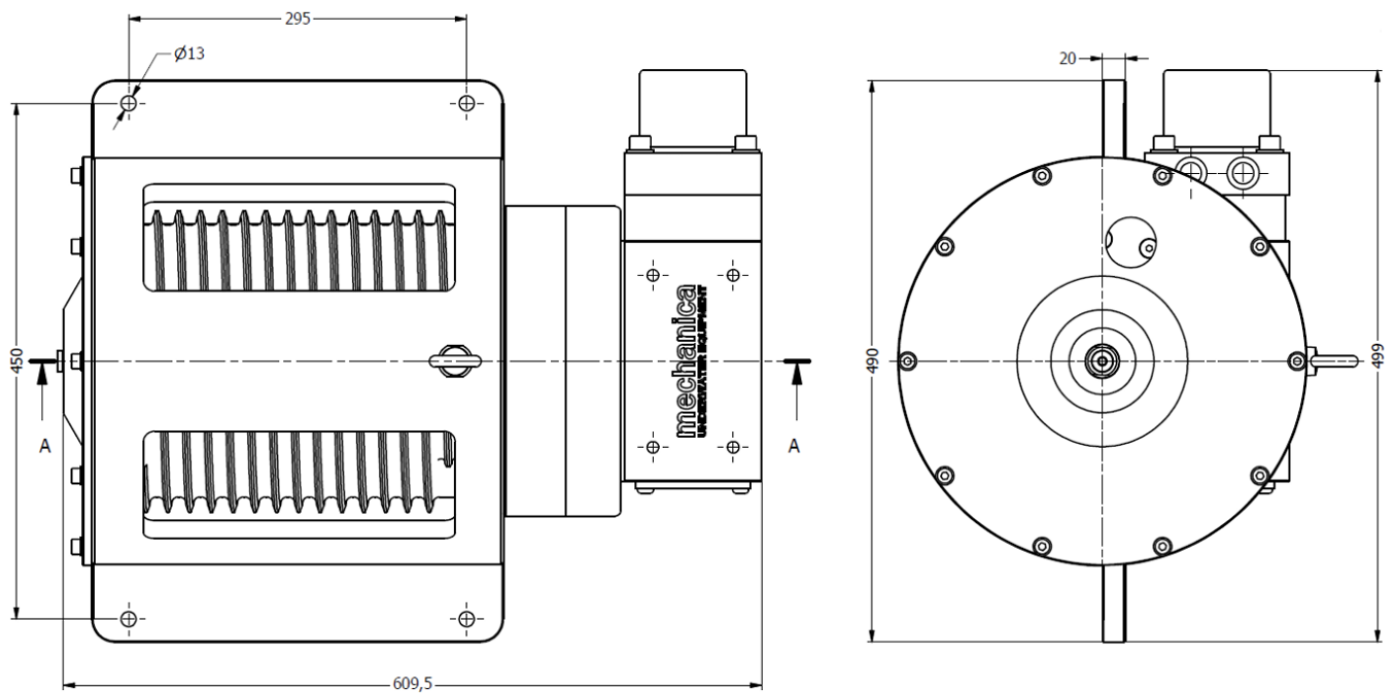

■ The specification details are illustrative for marketing purpose only. Actual equipment may be different as a result of product improvement or other reasons. Specific interface and performance information should be reconfirmed at time of order placement. Envirent AS, Robotvegen 16, 4340 Bryne, +47 477 77 500, sales@envirent.no

SPECIFICATIONS

5T SUBSEA WINCH

Inventory List:

Items listed in Inventory List are delivered with the equipment as standard. Any additional equipment must be specified upon order.

Item	Description	Total Qty	PN
1.	Hot Stab Ø35 2x Port w/CV - 10K	1	
2.	Hydraulic Hose ¼" Jic 4 Fm – Fm, 4m. SS	2	
3.			
4.			
5.			
6.			
7.			
8.			
9.			
10.			

■ The specification details are illustrative for marketing purpose only. Actual equipment may be different as a result of product improvement or other reasons. Specific interface and performance information should be reconfirmed at time of order placement. Envirent AS, Robotvegen 16, 4340 Bryne, +47 477 77 500, sales@envirent.no