

BACKPACK TRAY 3 X 50L COMP

LVDT
150L RESERVOIR
CONFIGURABLE DESIGN

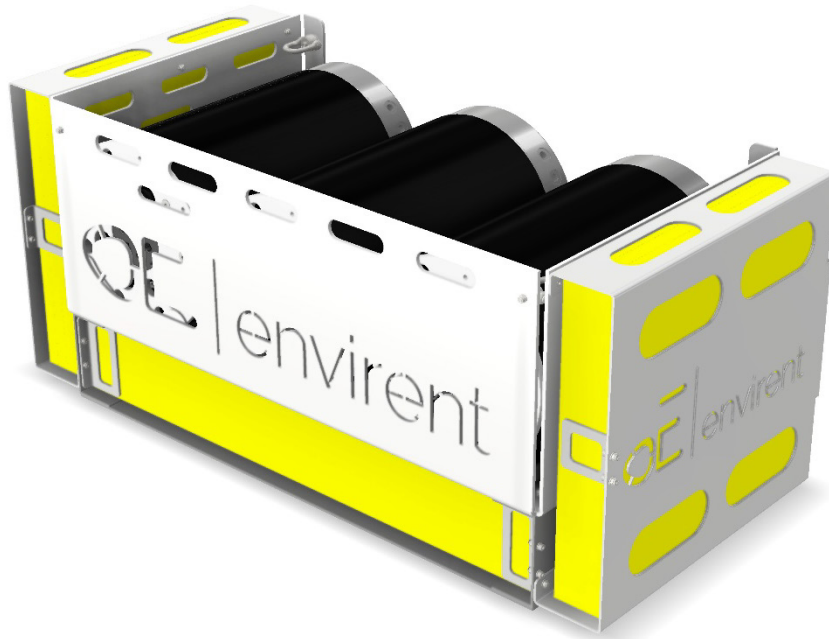

Description

This backpack tray features three 50-liter compensators and a configurable design, allowing easy adaptation to different operational requirements.

The integrated buoyancy system reduces effective weight in water while providing controlled lift and stability. Its streamlined, space-efficient design ensures compatibility with most ROVs without adding unnecessary bulk. Buoyancy elements can be removed or adjusted. The compensators can also be repositioned or configured to free up space for additional equipment, such as pumps or other tooling, increasing overall system flexibility.

An integrated LVDT enables accurate digital readout directly from the ROV, supporting reliable monitoring and control.

Typical Operations

- ▣ Tooling Operations
- ▣ Subsea Installation and Intervention
- ▣ IMR Operations
- ▣ Survey Support Tasks
- ▣ Extra Fluid Reservoir System

Features

- ▣ Three 50L Compensators
- ▣ Configurable and modular design
- ▣ Removable/adjustable buoyancy system
- ▣ Compact design and ROV compatible
- ▣ Integrated LVDT for digital feedback
- ▣ Optimized for stability and weight reduction in water

▣ The specification details are illustrative for marketing purpose only. Actual equipment may be different as a result of product improvement or other reasons. Specific interface and performance information should be reconfirmed at time of order placement. Envirent AS, Robotvegen 16, 4340 Bryne, +47 477 77 500, sales@envirent.no

SPECIFICATIONS

BACKPACK TRAY 3 X 50L COMP

General Technical Specifications

Type	Backpack Tray 3 x 50L Comp
Part Number	BP-TRAY
Dimensions L x W x H	1600 mm x 768 mm x 706 mm
Weight in air / submerged (No blocks removed)	370 kg / -50 kg
Weight in air / submerged (3 big blocks removed)	345 kg / 10 kg
Depth Rating	450 MSW

Electrical Interface

Nominal Voltage	20...30VDC
Signal Type	4-20 mA
Connector	55 Series, Shell Size 15, 8-Pins

Pin-Out

PWR & COMS

- Pin 01 – 0 VDC
- Pin 02 – 24 VDC
- Pin 03 – 4-20 mA
- Pin 04 – NC
- Pin 05 – NC
- Pin 06 - NC
- Pin 07 – NC
- Pin 08 – NC

Connector Face View

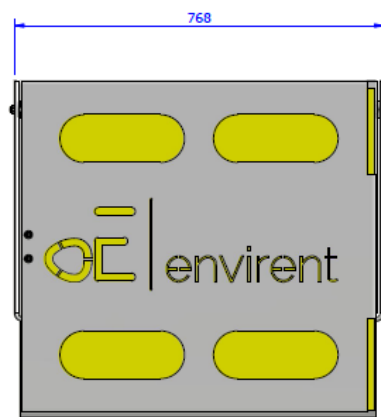
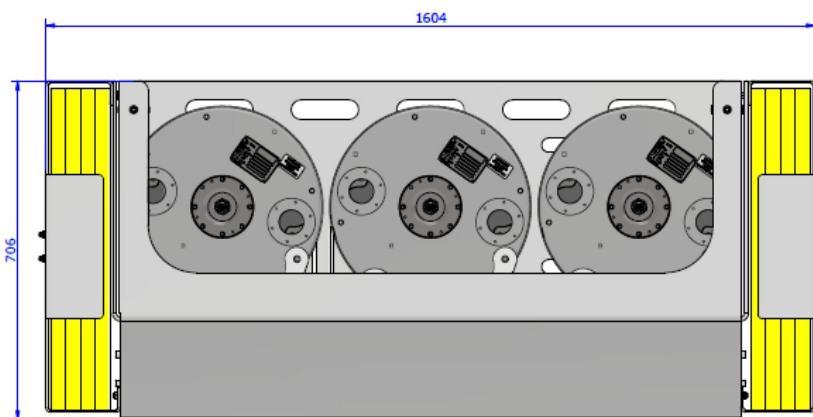
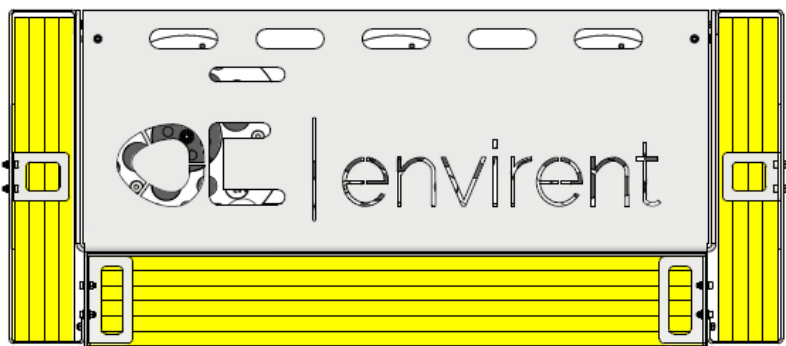
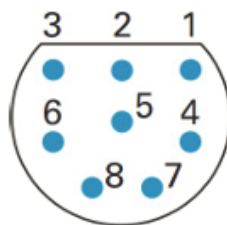

□ The specification details are illustrative for marketing purpose only. Actual equipment may be different as a result of product improvement or other reasons. Specific interface and performance information should be reconfirmed at time of order placement. Envirent AS, Robotvegen 16, 4340 Bryne, +47 477 77 500, sales@envirent.no

SPECIFICATIONS

BACKPACK TRAY 3 X 50L COMP



Inventory List:

Items listed in Inventory List are delivered with the equipment as standard. Any additional equipment must be specified upon order.

Item	Description	Total Qty	PN
1.			
2.			
3.			
4.			
5.			
6.			
7.			
8.			
9.			
10.			

□ The specification details are illustrative for marketing purpose only. Actual equipment may be different as a result of product improvement or other reasons. Specific interface and performance information should be reconfirmed at time of order placement. Envirent AS, Robotvegen 16, 4340 Bryne, +47 477 77 500, sales@envirent.no