

# 20FT SUBSEA BASKET

PAYLOAD  
W/REMOVABLE WALLS  
ISO CORNERS

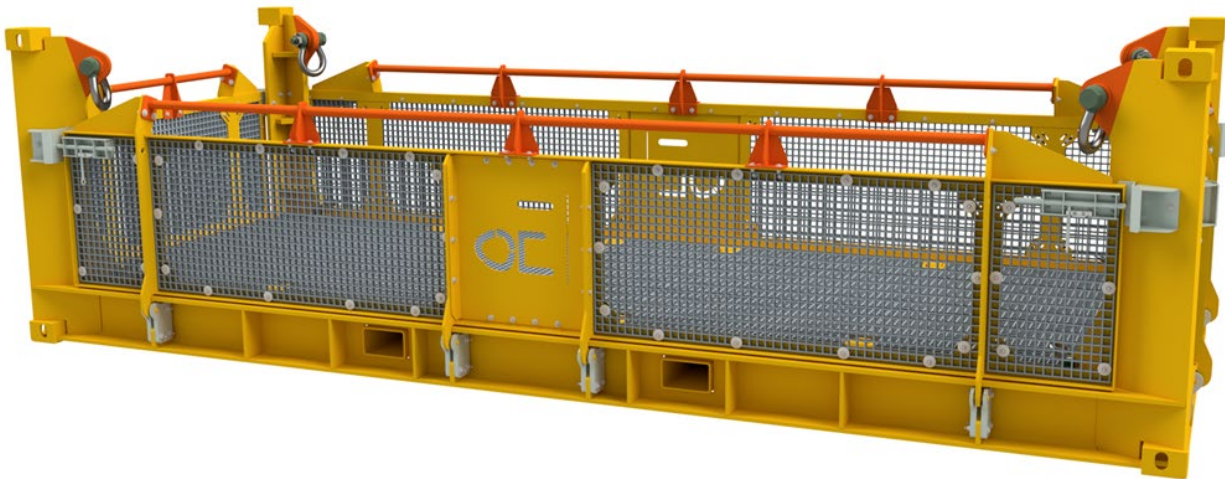

## Description

The 20 ft Subsea Basket is a durable offshore unit designed for safe transport and handling of equipment in subsea environments. It features ISO corner fittings for compatibility with standard lifting and transport systems.

The basket is equipped with removable walls on all sides, allowing full access and flexible loading from any direction. Each side can be opened independently and secured using a slide bolt locking system.

Four lifting padeyes are integrated into the structure to ensure safe and balanced lifting operations. The design provides strength, accessibility, and operational efficiency for offshore use.

- The specification details are illustrative for marketing purpose only. Actual equipment may be different as a result of product improvement or other reasons. Specific interface and performance information should be reconfirmed at time of order placement. Envirent AS, Robotvegen 16, 4340 Bryne, +47 477 77 500, sales@envirent.no

## Typical Operations

- Tooling Operations
- Subsea Storage Operations
- Intervention Operations

## Features

- ISO corner fittings
- Removable walls on all sides
- Slide bolt locking system
- Four lifting padeyes
- ROV grabber bar on all sides

# SPECIFICATIONS

## 20FT SUBSEA BASKET

### General Technical Specifications

Type	20 Ft Subsea Basket
Part Number	BASKET-SUB-20FT
Outside Dimensions L x W x H	6179 mm x 2535 mm x 1730 mm
Weight in air / submerged	5137 kg / 4328 kg
Depth Rating	3000 MSW

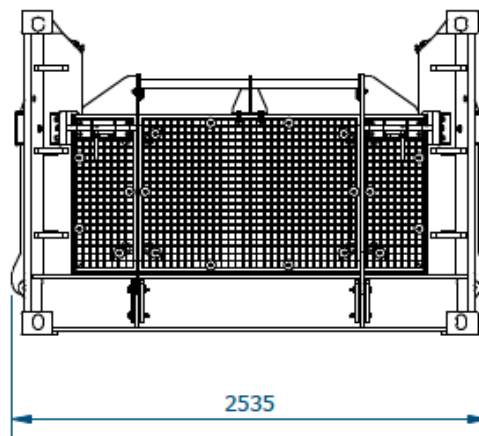

VIEW2  
( 1 : 40 )

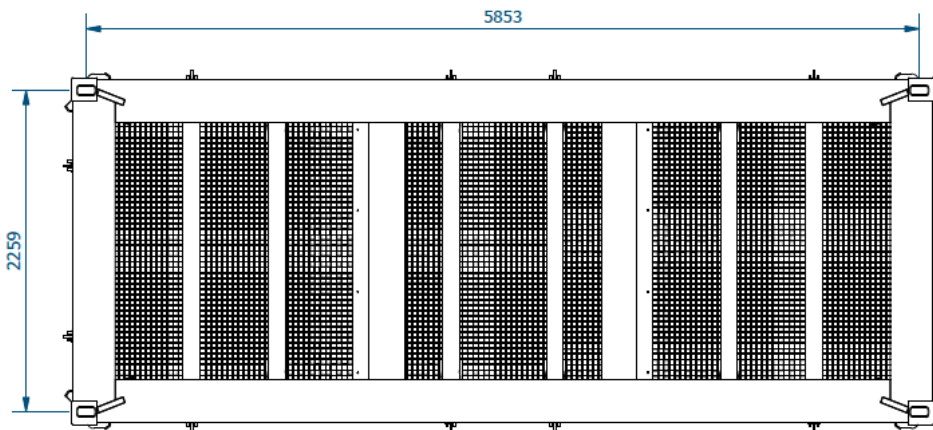

VIEW3  
( 1 : 40 )

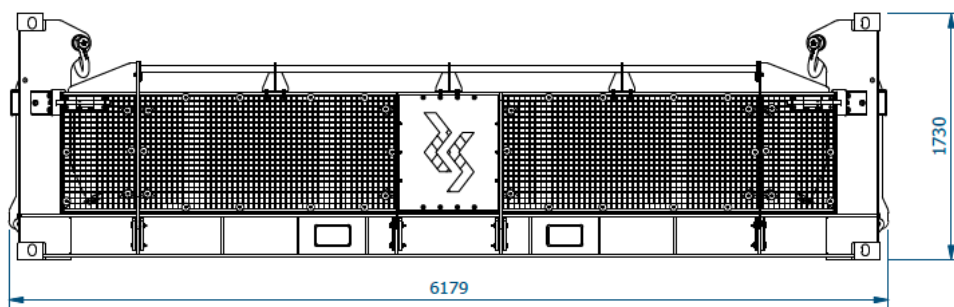

■ The specification details are illustrative for marketing purpose only. Actual equipment may be different as a result of product improvement or other reasons. Specific interface and performance information should be reconfirmed at time of order placement. Envirent AS, Robotvegen 16, 4340 Bryne, +47 477 77 500, sales@envirent.no

# SPECIFICATIONS

## 20FT SUBSEA BASKET

### Inventory List:

Items listed in Inventory List are delivered with the equipment as standard. Any additional equipment must be specified upon order.

Item	Description	Total Qty	PN
1.	Lifting Certificate	1	

■ The specification details are illustrative for marketing purpose only. Actual equipment may be different as a result of product improvement or other reasons. Specific interface and performance information should be reconfirmed at time of order placement. Envirent AS, Robotvegen 16, 4340 Bryne, +47 477 77 500, sales@envirent.no