

# ImpactSubsea

Innovative Underwater Products

## ISM3D – Heading, Pitch & Roll Sensor



Impact Subsea is proud to present the ground breaking **ISM3D** family of **Underwater Attitude and Heading Reference System (AHRS) Sensors**. Highly robust, compact and lightweight sensors providing **Heading, Pitch and Roll**.

The ISM3D utilises MEMS based Accelerometers, Angular Rate Gyroscopes and Magnetometers.

The outputs from each sensor are processed by an advanced fusion algorithm to provide highly **stable and accurate** Heading, Pitch and Roll.

The **ISM3D** is provided in a highly robust Titanium or Delrin® housing. Alternative OEM configurations are available upon request.

### Features

#### Heading

### Benefits

Provides Heading to  $\pm 0.5^\circ$  of Local Magnetic North

#### Pitch & Roll

Provided to  $\pm 0.07^\circ$  Accuracy

#### Titanium Housing

Robust & Depth Rated to 6,000 Meters

#### Optional Delrin Housing

Low Weight

#### SeaView Software

Configure Sensor, View & Log Data

#### Emulate Any Device

Direct Replacement of Existing Equipment

### Applications

ROV & AUV Heading & Attitude

Equipment Deployment Monitoring

Motion Reference Unit (MRU)

Auto Heading

Replacement for Flux Gate Compass

Replacement for Magnetically Slaved Gyro

[www.impactsubsea.com](http://www.impactsubsea.com)

# ImpactSubsea

Innovative Underwater Products

## ISM3D – Heading, Pitch & Roll Sensor

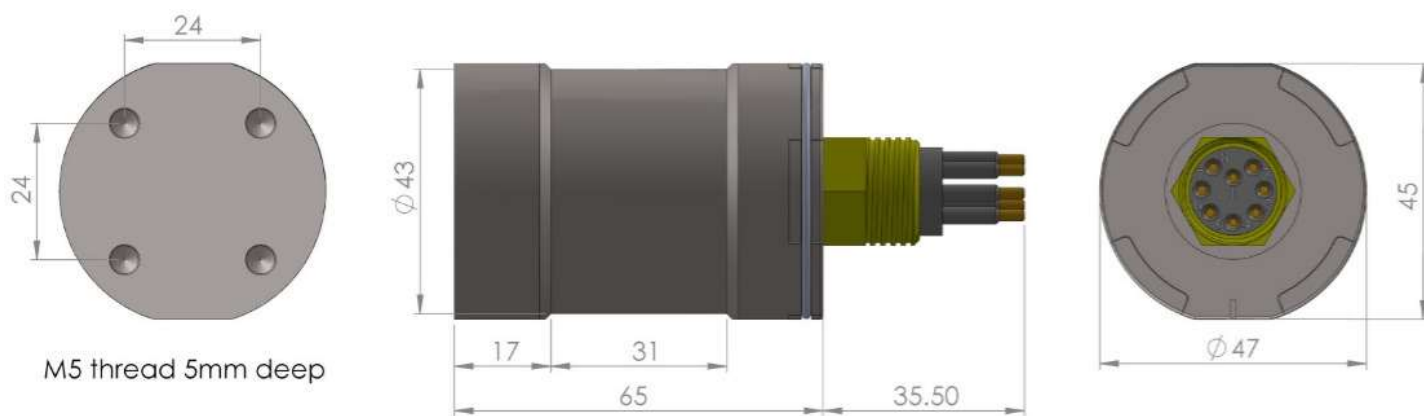

Standard connector & housing shown - other connector options are available.

All dimensions are in mm.

Heading	
Accuracy	± 0.5° of Local Magnetic North
Resolution	0.1°
Communications & Power	
Digital	RS232 & RS485
Protocol	300 to 115,200 baud
Data	Continuous or on demand
Data Rate	Up to 250Hz
Input Voltage	7 to 32V DC
Power	29mA @ 24V DC

Attitude	
Pitch	± 90°
Roll	± 180°
Accuracy	± 0.07°
Resolution	0.01°
Physical	
Weight (Air / Fresh Water)	0.33/0.225kg (Titanium) 0.20/0.10kg (Delrin®)
Depth Rating	6,000m (Titanium) 1,000m (Delrin®)
Temperature	-10 to 50° operating -20 to 70° storage
Connector	Subconn MCBH8M-SS other options available

Specifications subject to change in line with product enhancements. Rev 1.1

[sales@impactsubsea.co.uk](mailto:sales@impactsubsea.co.uk)  
 +44(0)1224 460 850  
[www.impactsubsea.com](http://www.impactsubsea.com)